

Model 10.61

The **Model 10.61** incorporates LSI's renowned durability into an economically priced Print & Apply Tamp label applicator. Based on Sato's Lt408 print engine, the **Model 10.61** prints text, barcodes and graphics, at speeds up to 6 IPS with a 203 DPI resolution, in both direct thermal and thermal transfer modes.

Every **Series 10.61** labeler features:

- Standard PLC based controls system with factory set parameters
- Model 060 3" Stroke Tamp Applicator with Rubber Tamp Pad
- Diffuse Reflective Product Sensor
- Sato 408Lt Thermal Transfer Printer, 4.25" media width, 203 DPI, 6 IPS – Serial Interface
- Alarm Package - Label Out/Low Ribbon/Ribbon Out with Alarm Light on Front Panel of Labeling Head
- 12" OD Unwind Roll Capacity
- Separately Driven Powered Rewind
- Integrates with Label Generation Software including Label View and Easy Label

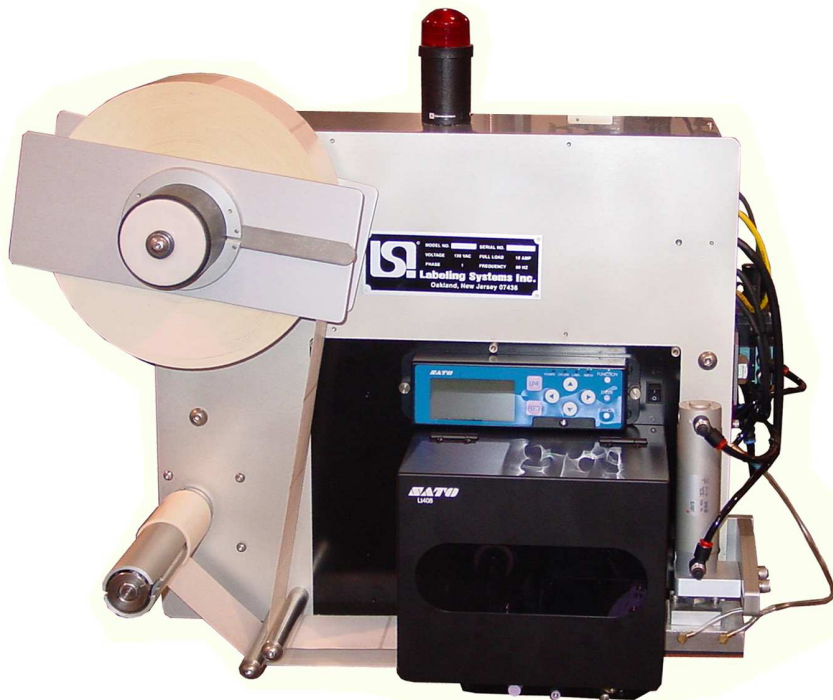

Options:

- Available in Right or Left Hand Configurations
- Tamp / Blow Functionality available.
- Parallel, Ethernet or Wireless Printer Interfaces
- 3", 6" or 8" Stroke
- 25 standard tamp pad sizes (see grid on page 2)
- Non-standard tamp pad sizes up to 4" (W) x 6" (F)
- Optional Alarm - Low Label Sensor & Beacon
- Universal Photoeye Mounting Bracket
- 6" Unwind Core Adapter
- LCD Display with Recipe Storage
- Remote Display Mounting
- Model 105 T Base Stand with Locking Castors



Remote Display Mounting Kit



Labeling Systems Inc.

32 Spruce Street
Oakland, NJ 07436
Tel: (201) 405-0767
Fax: (201) 405-1179
Email: LSI@LabelingSystems.com
www.labelingsystems.com

Specifications

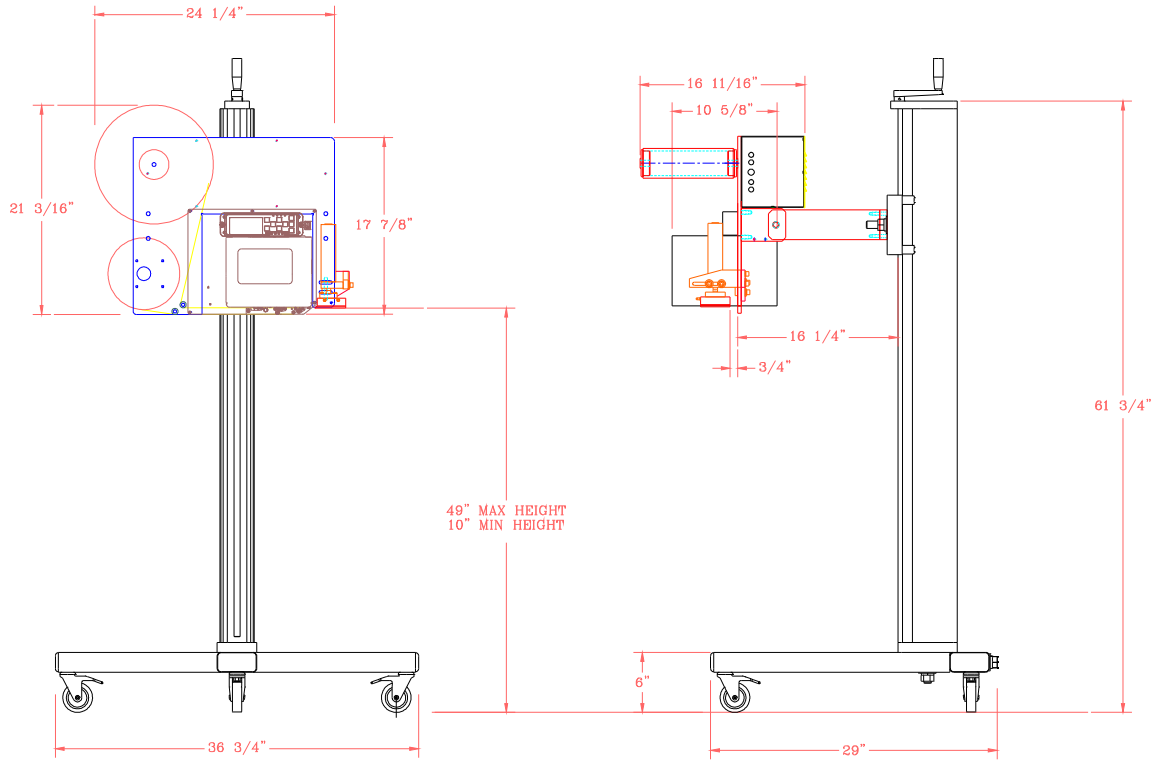

Applicator Options			
Tamp Pad Sizes	2" (W) x 2" (F)	3" (W) x 2" (F)	4" (W) x 2" (F)
	2" (W) x 3" (F)	3" (W) x 3" (F)	4" (W) x 3" (F)
	2" (W) x 4" (F)	3" (W) x 4" (F)	4" (W) x 4" (F)
	2" (W) x 5" (F)	3" (W) x 5" (F)	4" (W) x 5" (F)
	2" (W) x 6" (F)	3" (W) x 6" (F)	4" (W) x 6" (F)
	Non-Standard Tamp Pads up to 4" (W) x 6" (F).		
Stroke Options	3" stroke length is standard. 6" and 8" optional extended stroke lengths are available.		
Tamp / Blow Applicator	Tamp/Blow Functionality is available.		

Labeling Systems Inc.
 32 Spruce Street
 Oakland, NJ 07436
 Tel: (201) 405-0767
 Fax: (201) 405-1179
 www.labelingsystems.com
 Email: LSI@LabelingSystems.com