

MODEL e300

Label Applicator

- Rugged, Modular, Simple
- Variable speed up to 1,000" per minute
- Up to 5" wide label
- PLC Controls with touchscreen display
- Ambidextrous design for added flexibility
- Choice of Wipe-on or Tamp Applicator

The Model e300 is part of LSI's line of economy labeling solutions with a variable speed motor that achieves speeds up to 1,000 inches of label web per minute. The modular, simple, user friendly design sets this applicator above the competition. Available as a wipe-on or tamp applicator, it's ideal for the application of a wide assortment of sizes and shapes of pressure sensitive labels to the top, bottom or side of a product.

While economical, the e300 is a rugged industrial-duty applicator. The anodized aluminum construction provides protection from corrosive environments. With the ambidextrous left-hand and right-hand design, added flexibility is obtained and allows for changeover in the field. The simplistic design results in minimal downtime, easy fault diagnosis as well as minimal parts inventory.

A brightly lit, touch-screen display offers complete, easy user interface. A change in background color from green to orange to red gives quick, highly visible applicator status. An optional kit provides for moving the interface from the face plate to a location away from the applicator.



Model e300 Label Applicator

Right Hand, Wipe-on Version Shown

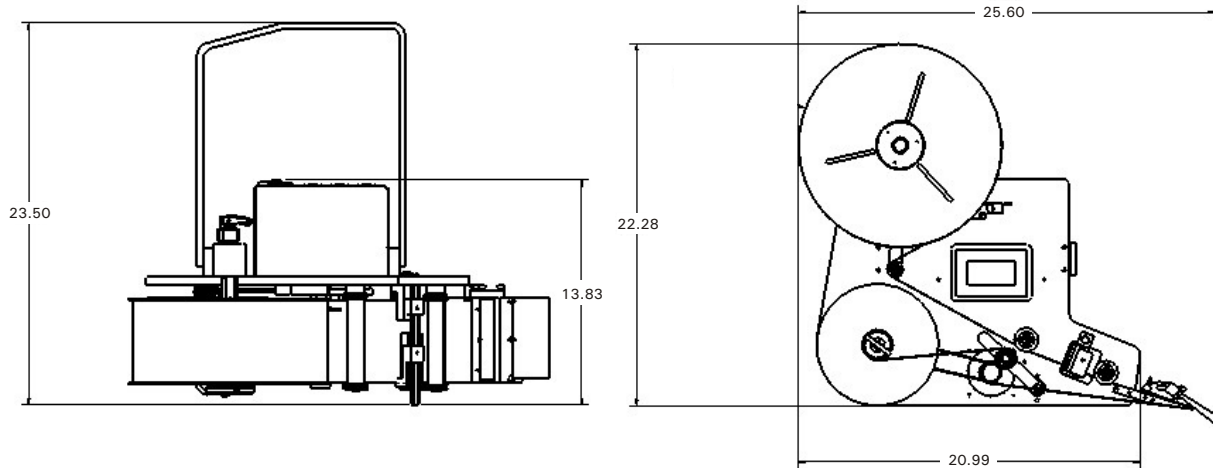

Note: All photography and dimensional drawings depict representative examples of systems. Dimensions, options and controls vary by application.

Model e300 Label Applicator Specifications

Weight	45 lbs.
Labeling Rate	Up to 1,000 inches of label web per minute
Label Placement Accuracy	Approximately +/- 1/16"
Label Size	5" x 12" Maximum .5" x .5" Minimum
Label Roll Size	12.5" (OD) x 3" (ID), Unpowered unwind
Electrical	115/230 VAC, 3 amp, 50-60 HZ
Air Requirements	Clean air at 80psi min. to 120psi dependent upon the application rate
Label Sensing	Photoelectric
Motor	Two Phase Stepper
Options	Wipe-on Tamp Tamp-Blow Model 105 T-Base Stand Low Label / Web Break Alarm 3 Stage Beacon Remote Display Kit



32 Spruce St.
Oakland, NJ 07436
201.405.0767